

REVISIONS			
LTR	DESCRIPTION	DATE	APPROVAL

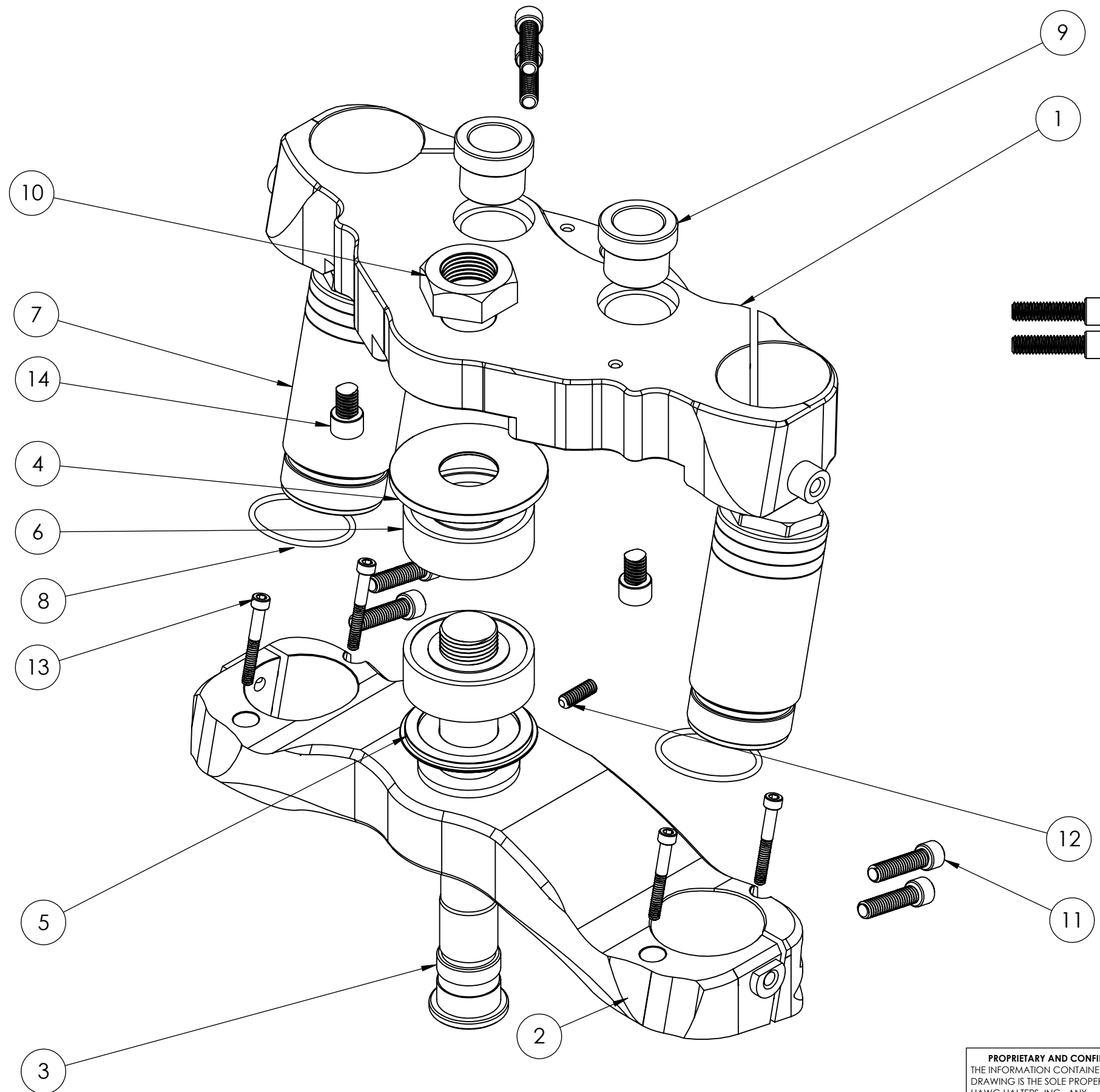

ITEM	QTY	P/N	DWG #	DESCRIPTION
1	1	49FLMR12S-30-U	45-2401	UPPER TREE
2	1	49FLMR12S-30-L	45-2402	LOWER TREE
3	1	NS-7	35-105	NECK STEM
4	1	UDS-004	45-505	UPPER DUST SHIELD
5	1	LDS-005	45-506	LOWER DUST SHIELD
6	2	--	--	HHI BEARING
7	2	FTI49-FLH+2	45-2101	FORK TUBE INSERT
8	2	MCM-9262K735	--	49-FTI O-RING
9	2	41-RBS-STK	45-1203	RISER BUSHING SPACER
10	1	FAST-1127	--	FL JAM NUT
11	8	FAST-93257	--	5/16-18 x 1.25" SHCS
12	1	MCM-90251A578	--	5/16-18 x 0.5" SET SCREW
13	4	FAST-01305504	--	10-24 x 1.5" SHCS
14	2	FAST-93301	--	3/8-16 x 1/2" SHCS

PROPRIETARY AND CONFIDENTIAL
 THE INFORMATION CONTAINED IN THIS DRAWING IS THE SOLE PROPERTY OF HAWG HALTERS, INC. ANY REPRODUCTION IN PART OR AS A WHOLE WITHOUT THE WRITTEN PERMISSION OF HAWG HALTERS, INC. IS PROHIBITED.

TOLERANCES UNLESS NOTED: X.X: +/- .03 X.XX: +/- .01 X.XXX: +/- .005 FRAC: +/- 1/16 ANGULAR: +/- 1°		DRAWN	NAME	DATE	PART NO.
MATERIAL		CHECKED	NBG	4/3/2014	49FLMR12S
FINISH --		ENG APPR.			PART: 49FL 12 DEG TREE SPECIAL KIT
NEXT ASSY USED ON		MFG APPR.			ASSEMBLY: 49 FLH 2014-UP SHORT NECK
APPLICATION		Q.A.			SIZE DWG. NO. REV.
DO NOT SCALE DRAWING		STOCK SIZE:			B 45-2400

HHI **Hawg Halters, Inc.**
 389 Lumpkin County Parkway
 Dahlonega, GA 30533