

REVISIONS			
LTR	DESCRIPTION	DATE	APPROVAL

P/N	A	B
FTI49-FLH	2.39	1.60
FTI49-FLH+1	3.39	2.60
FTI49-FLH+2	4.39	3.60

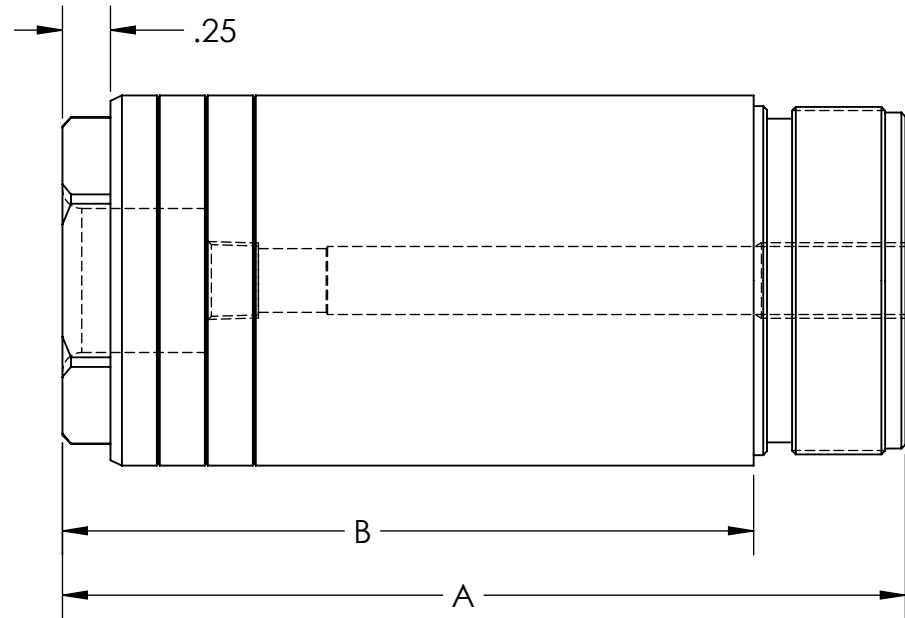
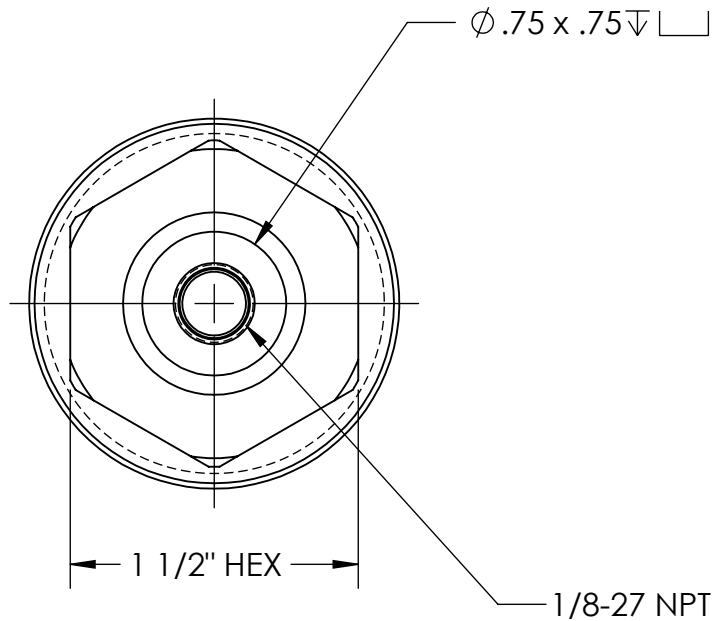

**Hawg Halters, Inc.**  
 389 Lumpkin County Parkway  
 Dahlonega, GA 30533

**PROPRIETARY AND CONFIDENTIAL**  
 THE INFORMATION CONTAINED IN THIS DRAWING IS THE SOLE PROPERTY OF HAWG HALTERS, INC. ANY REPRODUCTION IN PART OR AS A WHOLE WITHOUT THE WRITTEN PERMISSION OF HAWG HALTERS, INC. IS PROHIBITED.

		TOLERANCES UNLESS NOTED: X.X: +/- .03 X.XX: +/- .01 X.XXX: +/- .005 FRAC: +/- 1/16 ANGULAR: +/- 1°	NAME	DATE	PART NO.
		MATERIAL	DRAWN	NBG 6/16/2016	TABULATED
		FINISH	CHECKED		PART:
			ENG APPR.		FLH 49mm FORK BOLT
			MFG APPR.		ASSEMBLY:
			Q.A.		FLH 49mm FORK
NEXT ASSY	USED ON		STOCK SIZE:		SIZE
			Ø 2"		DWG. NO.
APPLICATION	DO NOT SCALE DRAWING				45-2101
					REV.
					WEIGHT:
					SHEET 2 OF 2