

2012 Summer Catalog

HAWG HALTERS, INC.

HHI

**Start With
The Best,
Stop With
The Best!**



**www.
HawgHalters
.com**

**Engineering
the Ultimate in
Show Quality
Performance
Parts!**



**"Start with the best,
Stop with the best"**

...Continues to be the driving force behind what we do at Hawg Halters.

We strive to design and manufacture the best engineered products so you can get the maximum enjoyment out of your investment. We utilize the latest technologies in Solids based computer aided design and finite element analysis to perfect the product design. We select materials like aircraft grade 6061 billet aluminum custom made to our specifications and stainless steel alloys to produce the best performing products available. Extensive prototyping and testing is done to optimize the design so it will perform long into the future.

Determining the most efficient manufacturing methods for each component is also one of our talents. With the use of Solids based computer aided manufacturing and CNC high speed machining centers we offer the best value for you. But the real key to all of this is

quality and customer satisfaction. All of our products are manufactured to strict quality assurance guidelines. Parts go through detailed inspection using the most advanced computer controlled inspection technology providing precise measurements and unbeatable quality. We then take great pride in providing our polished, chromed and anodized parts finished to industry leading show quality standards. Everything is assembled by experienced craftsmen and sent through for final inspection to again insure proper operation for complete customer satisfaction. All that's left is packaging to ensure your parts arrive in perfect condition.

We ride what we build and believe we manufacture the finest American made products for your American V-Twin motorcycle. We're craftsmen, perfecting the art and science of custom bike building...

**"Start with the best,
Stop with the best!"**

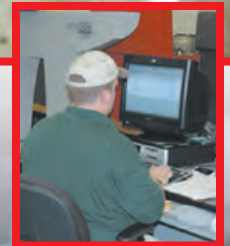

GENERAL POLICY

HHI sells to motorcycle businesses and the general public. Orders can be placed by calling our toll free number Monday-Friday 8:00am-5:00pm EST. You can also fax your order in 7 days a week, 24 hours a day. Dealer inquiries can be made by calling directly. To qualify for dealer pricing, an approved dealer application must be on file prior to ordering.

PRICES

HHI reserves the right to change pricing, terms and conditions without notice.

TERMS

All orders are shipped pre-paid or COD/ Certified Cashiers Check or Money Order. We also accept Visa, MasterCard, Discover and American Express. Shipping and handling fees will apply. Pre-arranged pre-payment is accepted, as some orders require a 50% deposit to be paid at time of order. 7% sales tax applies to Georgia residents. Georgia dealers must have a tax re-sale certificate on file prior to ordering to be sales tax exempt.

FOREIGN ORDERS

All foreign orders must be pre-paid in U.S. dollars only. Wire Transfer fees may apply.

RETURNS & EXCHANGES

HHI requires that you contact us directly so an RGA (Returned Goods Authorization) number can be issued BEFORE you return product. Please write the RGA number on the outside of the box for identification purposes. All product returns and exchanges are subject to inspection for determination of credit and/or refund. Credits/refunds will be issued for the amount of the merchandise only, less a restocking fee. No refunds will be issued after 30 days.

If pre-arranged with HHI, we will ship out a replacement part to you and provide you with a pre-paid return shipper label for product to be exchanged. In the event we do not receive the original shipped part back in "as new" condition within 2 weeks of you receiving the replacement part, you will be charged for the exchange.

BACK ORDERS

Products temporarily out of stock are automatically shipped when they become available. Back orders over 30 days are verified with the customer prior to shipping.

SHIPPING

All orders are shipped UPS Ground. You may request your order to be shipped Next Day Air, 2nd Day Air, 3 Day Select or Saturday Delivery

for an extra charge. Transactions for orders placed by credit card will not be processed until the day the order is shipped. All claims for loss or damage are to be made directly to UPS. We will assist when necessary. Tracking numbers are available the day of shipping.

PRODUCT CHANGES

HHI reserves the right to discontinue any product(s) as considered necessary. We also retain the right to make changes in design, construction or specifications of the product(s) we manufacture at any time without incurring any obligation to incorporate such changes in product(s) previously sold.

LIMITED WARRANTY

All HHI products sold or manufactured have a one year warranty from date of purchase against all material or workmanship defects. HHI assumes no responsibility for damages or injuries, which may result from the use or installation of its products, whether or not properly installed. HHI shall have no obligation hereunder in the event the products have been modified by any other person or organization, or where the products become defective in whole or in part as a result of improper installation, improper maintenance, improper use, abnormal operation or any other misuse or mistreatment of the product. HHI shall not assume any responsibility for special, incidental or consequential damages or costs incurred due to failure of the product. We make no claims as to the fitness of any particular use of our products, as the end use is the responsibility of the customer. HHI highly recommends test fitting all products prior to any modifications.

CHROME WARRANTY

HHI products are chrome plated to the highest quality. We take pride in our products, striving daily to provide you with top-rated show quality chrome. However, the life of your products appearance largely depends upon the environmental conditions and your care/maintenance. Chrome products should be maintained properly by regular cleaning with mild soap and water and waxing. Do not use abrasive cleaners. HHI reserves the right to determine if the product has been maintained properly and has not been abused. HHI warrants defects in material and workmanship of chrome plating for all products sold or manufactured for two years from the date of purchase. Applicable defects are peeling, cracking, blistering and/or separation of the plating from the product.

| |
|---|
| 6 Piston Front Calipers . 5 |
| 4 Piston Front Calipers . 6 |
| 4 & 6 Piston Caliper and Floating Rotor Packages 7 |
| 4 and 6 Piston Front Caliper Kits 8 |
| 4 and 6 Piston Rear Caliper Kits 9 |
| Rear Caliper Kits For Rigids and Customs . 14 |
| Brake Hose Kits, Pads, and Rebuild Kits 15 |
| Drive Side In-Board Rear Brake Systems 16 |
| Sprocket-Brakes..... 18 |
| Forward Controls..... 20 |
| Bagger Forward Controls..... 23 |
| HellRazor HandleBars. 24 |
| Hand Controls 26 |
| Complete Front Ends .. 28 |
| Triple Trees..... 30 |
| Wheels..... 32 |
| Bagger Central 40 |
| Bagger Single Disc Conversion 41 |
| Bagger Fork Leg Packages 42 |
| 2012 Event Schedule .. 43 |

Most Hawg Halters products are available in your choice of three finishes - Polish, Chrome and Black Anodize. Just pick the look that's right for your project!



HawgHalters.com

**Local: 706-864-7800
Fax: 706-864-5843**

**389 Lumpkin County Parkway
Dahlonega, GA 30533**

4 and 6 Piston Front Brake Calipers

Hawg Halters, Inc. offers a complete line of 4 & 6 piston brake calipers for your American V-Twin. These calipers are engineered for maximum braking performance and show quality looks. Our front caliper applications are direct bolt on for 1984 and up models except the Springer. Direct bolt on provides the most rigid and cleanest attachment method of mounting. All calipers are manufactured from 6061 billet aluminum which provides a stronger more rigid caliper with less weight as compared to stock and some competitors cast aluminum product.

Our differential bore 4 and 6 piston calipers continue to be unmatched for performance and value. Utilizing a smaller diameter piston at the lead-in of the rotor and a larger piston on the trailing side provides optimum friction dynamics by equalizing the heat distribution throughout the brake pad to rotor interface. In addition, the differential bore ratio and total volumetric displacement are correctly sized to promote the best brake caliper response and brake lever feel. We also employ dual piston seals providing each piston with 2 layers of protection from contamination promoting long term leak proof operation. In addition, this sealing system improves piston pullback which reduces brake pad drag on the rotor. Further improvements have been made with specially designed permanent brake pad retainers providing quiet operation and an upgraded friction material promoting longer life and less pad dust.

As always, our calipers don't feature our logo so you get that smooth, clean, custom look. All calipers come complete with brake pads, mounting hardware, 10mm banjo bolt and crush washers for easy installation. HHI calipers are also compatible with either DOT 4 or DOT 5 brake fluid.



6 Piston Front Brake Calipers

LHSCC6013



RHSCC6000



LHSCC6001



RHSAB6001



LHSCC6000



(LH) Left Hand or (RH) Right Hand

- (S) Standard width or (N) Narrow width

- (CC) Chrome, (PP) Polish, (AB) Black Anodize

LHSCC6000

(6000) 1984-99 6 Piston Differential Bore, used with 11.5" rotor

- fits all H-D models except Springer and Narrow Glides with spoke wheel.
NG models must use a (N) narrow 6 piston caliper.

(6001) 2000-up 6 Piston Differential Bore, used with 11.5" rotor

- fits all H-D models except Springer, 06-up VROD & 08-up Touring Models

(6018) 2008-up 6 Piston Differential Bore, used with 11.8" rotor

- fits all 2008-up H-D Touring and 2006-up VROD models.

(6003) 1984-99 6 Piston Differential Bore

- fits H-D models when used with a 13" rotor
except Springer and Narrow Glides with spoke wheel.

(6013) 2000-up 6 Piston Differential Bore

- fits H-D models when used with a 13" rotor.



HawgHalters.com

Local: 706-864-7800

Fax: 706-864-5843

389 Lumpkin County Parkway
Dahlonega, GA 30533

4 Piston Front Brake Calipers



LHSCC500

RHSCC500

LHSAB500

RHSCC501

LHRLCC501

RHSCC350

(LH) Left Hand or (RH) Right Hand

(S) Standard Width

(RL) RoadLok™ MID Sniper

(CC) Chrome, (PP) Polish, or (AB) Black Anodize

LHSCC500

(500) 1984-99 4 Piston Differential Bore - Fits all H-D models except Springer and Narrow Glides with spoke wheel.

(501) 2000-up 4 Piston Differential Bore - fits all H-D models except Springer

(5018) 2008-up 4 Piston Differential Bore - fits all 2008-up H-D Touring and 2006-up VROD models with 11.8" Rotors.

(100) Springer and Rear Rigid Kits only (see pages 8 & 14 for applications)

(350) Universal Mount 4 Piston Calipers

The Evolution of Motorcycle Security
ROADLOK
 MOTORCYCLE IMMOBILIZATION DEVICE



New for 2010! 4 & 6 Piston Caliper and Floating Rotor Packages!



LHSAB501
4 Piston Caliper
and 11.5" Cobra
Black Rotor

Floating Rotors

Hawg Halters manufactures floating rotors in a variety of styles and sizes to fit most any application. HHI's Rotors provide superior heat dissipation under extreme braking conditions for a significant performance advantage over one piece solid rotors. They feature replaceable friction rings mounted to either chrome or black centers to match a variety of wheel styles. Available in 11.5", 11.8" and 13" diameters.

4 & 6 Piston Brake Calipers

Hawg Halters offers a complete line of 4 & 6 piston brake calipers for your American V-Twin. These calipers are engineered for maximum braking performance and show quality looks. HHI's Front Caliper applications are direct bolt on for 1984 and up models, including all 2010 HD Models.

Brake Caliper and Floating Rotor Packages start at \$499.
Call today for details.



LHSCC6013
6 Piston Caliper and
13" Venice Rotor



LHSCC501
4 Piston Caliper
and 11.5" Cobra
Chrome Rotor



HawgHalters.com

Local: 706-864-7800

Fax: 706-864-5843

389 Lumpkin County Parkway
Dahlonega, GA 30533

4 and 6 Piston Front Caliper Kits

HHI offers a full line of front brake caliper kits for the American V-Twin Market. These 4 & 6 piston caliper kits are designed for various applications including those which require special mounting brackets.



FKCLAB100



FKFL10CC100



FKCRCC100

(SBK-XXX)
Custom
Springer axle
bushing kits
available for many
applications.



FKSRCC100

(FK) Front Kit

- (DD)** Dual disc 84-99 & 2000-up
- (FL)** 73-83 FL Single Disc, 10" Rotor*
- (HS)** 90-08 FL Springer®*
- (WG)** 80-83 Wide Glide®, Dual Disc
- (SR)** 88-07 FXSTS Springer®*
- (CL)** Custom Springer, Left Side*
- (CR)** Custom Springer, Right Side*
- (CC)** Chrome, **(PP)** Polish,
or **(AB)** Black Anodize

FKSRCC100

- ***(100)** 4 Piston Symmetrical Bore caliper
used only as listed above
- (550)** 1984-99 Differential Bore Dual Disc -
fits all HD models except narrow glide
with spoke wheel
- (551)** 2000-up Differential Bore Dual Disc -
fits all HD models

4 and 6 Piston Rear Caliper Kits

HHI manufactures the most comprehensive product selection of rear brake calipers for the American V-Twin Market. Kits are available for models 1973 to present and most any custom bike including 1" & 25mm axle applications and right side drive.

Most kits feature the latest design 500 series differential bore caliper for optimum performance in your choice of finish: chrome, polish or black anodize.

(RK) Rear Kit

(ST) Softail® Models, Right Side Brake

(LS) Softail® Models, Left Side Brake

(FR) FXR Models

(DG) Dyna® Models

(SP) Sportster Models

(HT) FLH Models

(VR) VROD Models

(LX10) FX/FL 73-80, 10" Rotor

(LX11) FX/FL 81-83, 11 1/2" Rotor

(CC) Chrome, (PP) Polish,

(AB) Black Anodize

RKSTCC506

RKSTCC506

4 Piston Differential Bore Caliper Kits

1999-Earlier all models 3/4" Axle (500)

2000-07 all models 3/4" Axle (501)

2004 Sportster only (504)

2006-07 200mm tire Softail only (506)

1999-Earlier 1" Axle Softail (530)

2002-07 1" Axle FLH, 2002-05 VROD (532)

2005-07 Sportster (SP) (535)

2006-07 Dyna (536)

2008-Up 200mm tire Softail only (508)

2008-Up 25mm Axle All Models (548)

6 Piston Differential Bore Caliper Kits

1999-Earlier 3/4" Axle (6000)

2000-Up 3/4" Axle (6001)

1999-Earlier 1" Axle (6030)

2002-Up 1" Axle (6032)



HHI

HawgHalters.com

Local: 706-864-7800

Fax: 706-864-5843

389 Lumpkin County Parkway
Dahlonega, GA 30533



RKDGCC501



RKDGCC500



RKFRCC600

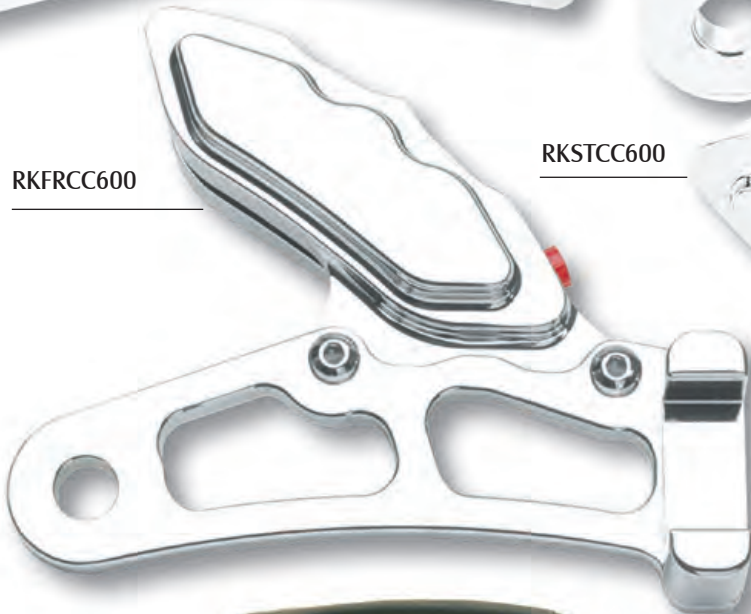

RKSTCC600



REAR CALIPER
INSTALLED
ON DYNA



HawgHalters.com

Local: 706-864-7800

Fax: 706-864-5843

389 Lumpkin County Parkway
Dahlonega, GA 30533



RKFRCC500



RKHTCC500



RKHTCC501



RKHTCC632

RKSPCC535



RKLX11CC500



RKSPCC500

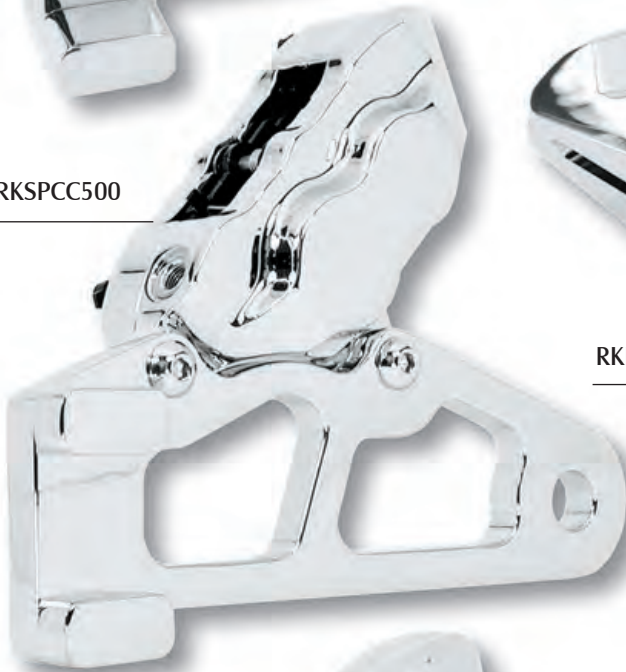

RKLX10CC500



RKSPCC501



HawgHalters.com

Local: 706-864-7800

Fax: 706-864-5843

389 Lumpkin County Parkway
Dahlonega, GA 30533

Rear Caliper Kits For Rigids and Customs

HHI Rear Kits for Rigid and Custom frame bikes use our time-tested 100 series symmetrical bore 4 piston caliper or 6 piston caliper. All kits include Heim joint assembly and 3/8" hardware as shown.

RKRD11CC630



RKLD11AB100



RKRD10CC300



(RK) Rear Kit

(RD10) Rigid Custom,
Right Side, 10" Rotor

(RD11) Rigid Custom,
Right Side, 11 1/2" Rotor

(LD11) Rigid Custom
Left Side, 11 1/2" Rotor

(CC) Chrome, **(PP)** Polish,

(AB) Black Anodize

RKRD11CC300

4 Piston 3/4" Axle **(100)**

4 Piston 1" Axle **(300)**

6 piston 3/4" Axle **(600)**

6 piston 1" Axle **(630)**

RKRD11CC100

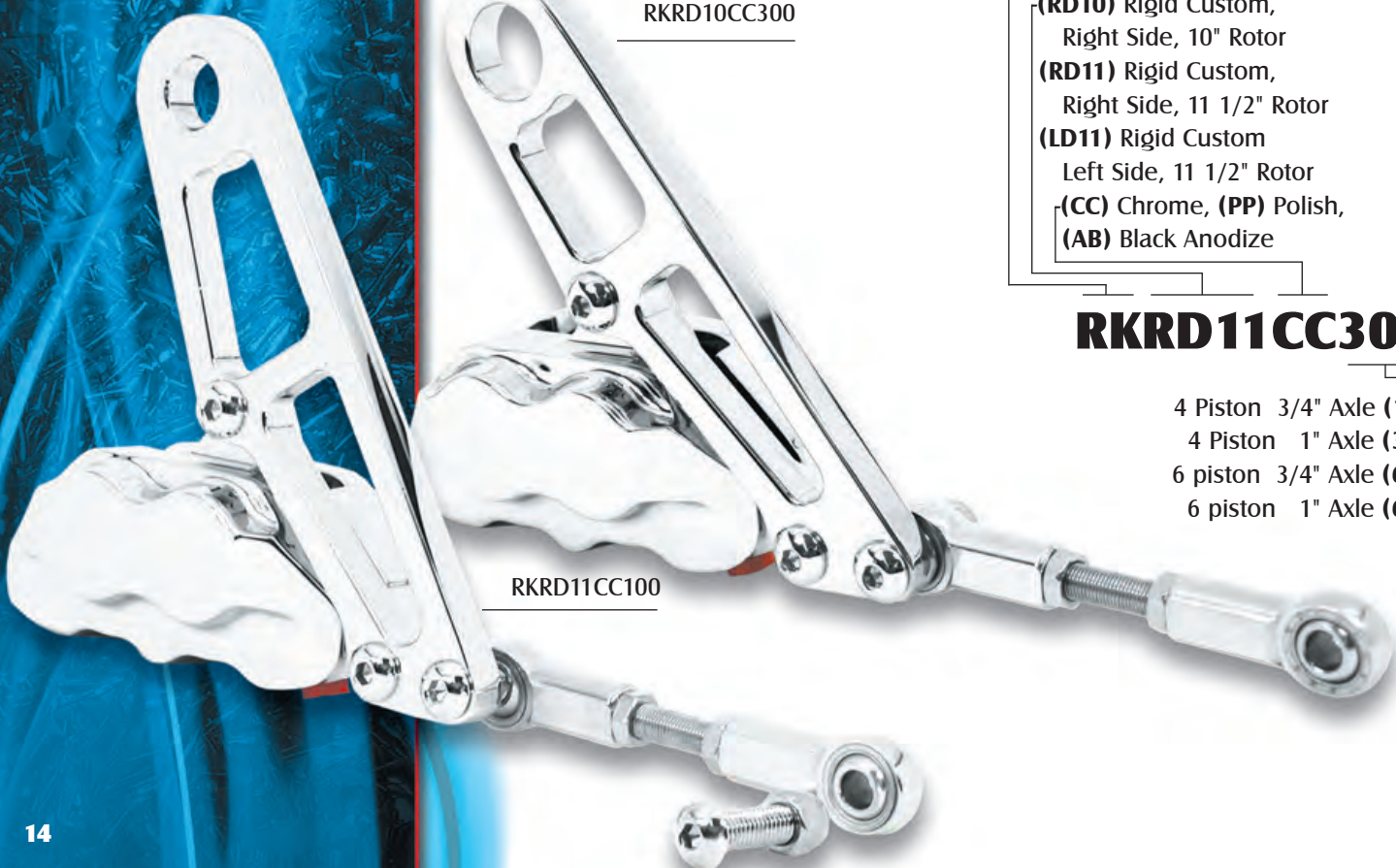

Brake Hose Kits

Brake hose kits are now in stock for most Softail applications when replacing stock hoses or converting to custom forward controls. Kits include clear coat covered braided stainless hoses with chrome ends, chrome fittings and brake tees.



BHK-001 - Stock Rear Brake/Master Cylinder, 2000-up Softail

BHK-002 - Stock Rear Brake, Custom Forward Controls, 2000-2006 Softail

BHK-003 - Driveside Inboard Rear Brake, Custom Forward Controls, 87-99 Softail

BHK-004 - Driveside Inboard Rear Brake, Extended Forward Controls, 87-99 Softail

BHK-005 - Stock Rear Brake, Custom Forward Controls, 87-99 Softail

BHK-006 - Stock Rear Brake, Extended Forward Controls, 87-99 Softail

BHK-007 - Stock Rear Brake, Custom Forward Controls, 2007-up Softail

Brake Pads

Brake pads supplied with our calipers are the organic based semi-metallic type. These pads offer good braking performance in wet or dry conditions and provide average pad life while minimizing rotor wear. Pads are also available in a high friction sintered metal type which provides more aggressive braking and increased pad life.



HHI-101-001 - 4 Piston Caliper Brake Pads - Semi-Metallic

HHI-101-001-S - 4 Piston Caliper Brake Pads - Sintered Metal

HHI-601-001 - 6 Piston Caliper Brake Pads - Semi-Metallic

HHI-601-001-S - 6 Piston Caliper Brake Pads - Sintered Metal

HHI-351-001 - 4 Piston Sprocket Caliper Brake Pads - Semi-Metallic

Rebuild Kits

HHI-101-002 - 100 Series Symmetrical Bore 4 Piston Caliper Rebuild Kit

HHI-501-002 - 500 Series Differential Bore 4 Piston Caliper Rebuild Kit

HHI-601-002 - 600 Series 6 Piston Caliper Rebuild Kit - Single Seal Style

HHI-601-003 - 6000 SERIES 6 Piston Caliper Rebuild Kit - Dual Seal Style

HHI-351-002 - 4 Piston Sprocket Caliper Rebuild Kit



HHI

HawgHalters.com

Local: 706-864-7800

Fax: 706-864-5843

389 Lumpkin County Parkway
Dahlonega, GA 30533

Drive Side In-Board Rear Brake Systems

HHI continues to set the standard with our ever popular Driveside Inboard Brake System. We now have several designs to fit more applications than any of our competitors.

This system is designed to locate the brake caliper and rotor behind the drive pulley or sprocket providing an uncluttered view of your custom wheels. Utilizing a purpose built version of our proven 4 piston caliper and an engineered attachment system, a bullet proof system can be configured to match your requirements. Applications include 18" x 5.5" and wider billet wheels and 18" x 8" and up spoke wheels, left or right side drive, belt or chain drive.

We have also developed an offset rotor system to fit most custom wheels available. You can adapt a wheel without an inboard rotor or convert a conventional wheel to the driveside brake set up. We also offer a variety of hub covers for the opposite hub side when removing the rotor.



(C) Complete Kit - includes rotor & hat, omit letter "C" when not required

(RKDS) Rear Kit Drive Side

(L) Left Side or

(R) Right Side

(CC) Chrome,

(PP) Polish, or **(AB)** Black Anodize

Axle size (Bracket)

(1) 3/4" Axle or **(3)** 1" Axle

CRKDSLCC315-RS-TLD

Belt width (**Spacer**)

1 1/2" Belt - Std, 1.77 wide spacer **(0)**

1 1/8" Belt/Chain, 1.40 wide spacer **(1)**

2" Belt, 2.00 wide spacer* **(2)**

Special, 2.25" wide spacer **(3)**

Hub to Pulley Back Spacing (**Rotor Hat**)

No hat or rotor supplied **(0)**

1/8" Offset, 1" axle - 1 1/2" belt **(1)**

1/8" Offset, 3/4" axle** - 1 1/2" belt **(2)**

1/8" Offset, 3/4" axle** - 1 1/8" belt **(3)**

1/8" Offset, 1" axle - 1 1/8" belt **(4)**

3/8" Offset, 1" axle - 1 1/2" belt **(5)**

1/4" Offset, 1" axle - 1 1/2" belt **(6)**

1/2" Offset, 1" axle - 1 1/2" belt **(7)**

(Optional) Single Tube Round Swingarm **(RS)**

(Optional) Chain Drive application **(CH)**

Optional Tag/Taillight, Left Side Diamond **(TLD)**

Optional Tag/Taillight, Right Side Diamond **(TRD)**

Optional Tag/Taillight, Left Side Moon **(TLM)**

Optional Tag/Taillight, Right Side Moon **(TRM)**

* Also used when 1 1/2" pulley does not have recessed mounting hardware.

** Early style tapered bearing hub. For sealed bearing hub with 3/4" axle, use (-1) 1" axle or (-4) hat.

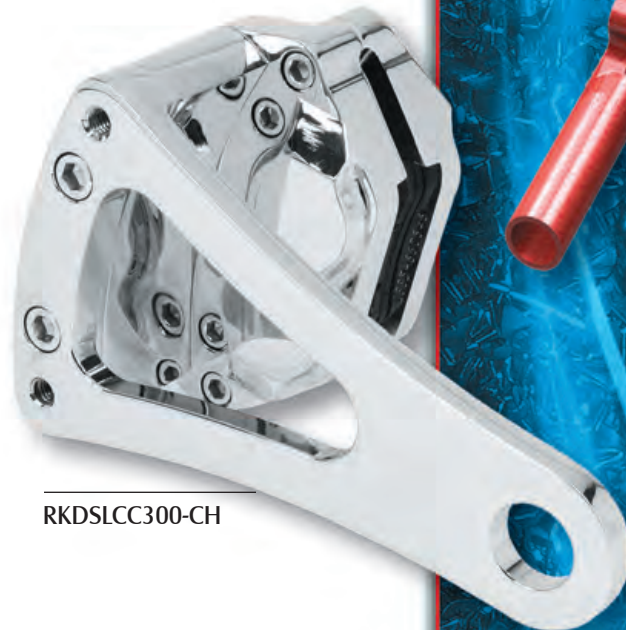
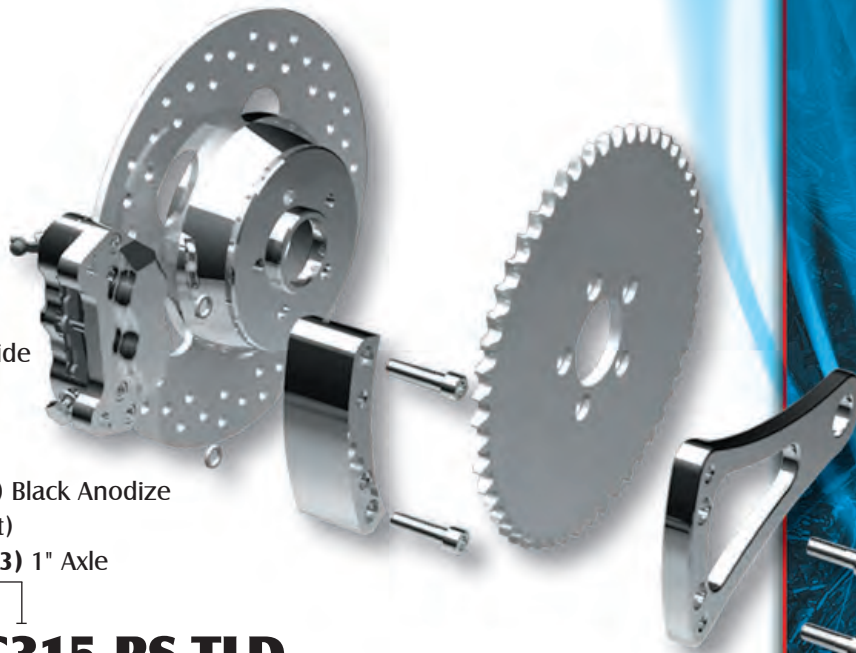

RKDSLCC300-CH



RKDSLCC300-RS-TLM

Taking it a step further is our integrated Driveside brake and tag holder/taillight kit. Based on our popular driveside brake, we designed a common bracket for mounting both the caliper and tag holder taillight combo. Available for standard, round swingarm and chain drive applications.

HHI

HawgHalters.com

Local: 706-864-7800

Fax: 706-864-5843

389 Lumpkin County Parkway
Dahlonega, GA 30533

Sprocket-Brake Systems

HHI has a proven product again with our sprocket brake system. Custom builders throughout the industry have attested to that. Using our four piston design and a proprietary brake pad configuration, we offer the ultimate in a sprocket brake.

The SPROCKET BRAKE kit features a four piston caliper design with an integral mount providing a bullet proof installation with no hassle. Everything centers on the axle and the sprocket for perfect alignment. No need to remove the caliper to bleed as the brake line port and bleeder location are right where you need them. The caliper comes equipped with a specially designed brake pad featuring twice the standard thickness of a specially formulated friction material providing extremely long life and minimum wear to the sprocket surface. The supplied 51 tooth sprocket is manufactured from 420 stainless steel, fully heat treated, blanchard ground with a show polish finish. With an aggressive vented design and the correct thickness to work with the heavy duty 530 size chain, these sprockets are made to last. Kits are available for both left and right side drive and work with $\frac{3}{4}$ " or 1" axles, early or late style wheels. Calipers are also offered separately and stocked in chrome, polish and black anodize finish.



(RKS) Rear Kit Sprocket Brake
(L) Left Side or **(R)** Right Side
(CC) Chrome, **(PP)** Polish
or **(AB)** Black Anodize

RKSBLCC351

Matching Front Rotor Available
LEFT HAND - **ROT-FLT-SPR**
RIGHT HAND - **ROT-FRT-SPR**



Transmission sprockets available in various offsets.

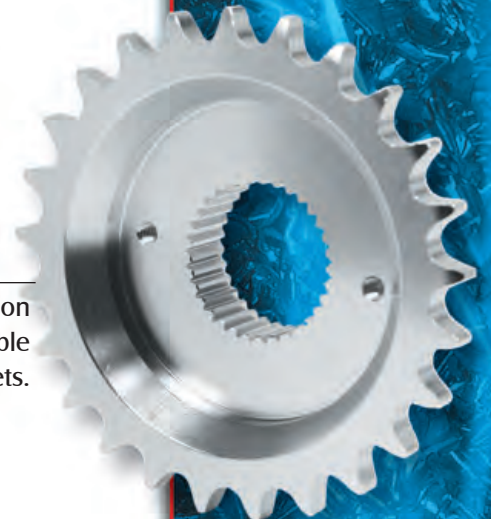

Nickel plated o-ring chains in stock.
CH-530-120

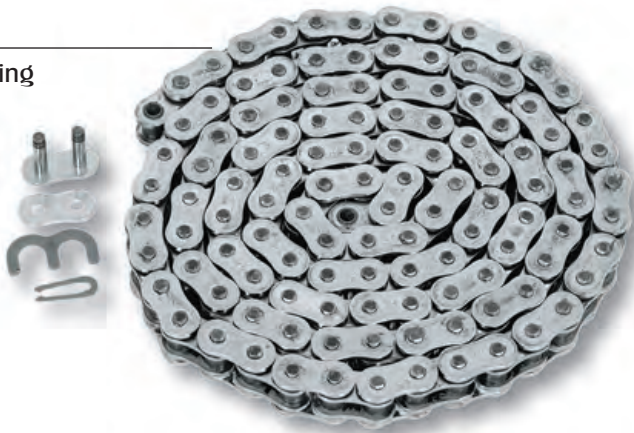

HHI

HawgHalters.com

Local: 706-864-7800

Fax: 706-864-5843

389 Lumpkin County Parkway
Dahlonega, GA 30533

Forward Control Systems

HHI continues to develop market leading forward control designs that provide sleek styling, sound engineering, superb performance and unequalled value. With kits to fit most applications and multiple styles to match, we're sure you'll find one that exceeds your expectations for fit, form and function.

Our new forward control features an 11/16" master cylinder bore size compatible with stock and most aftermarket rear calipers. It also utilizes interchangeable late model OEM components for easy serviceability.

Both the shifter and brake pivot assembly incorporate dual sealed ball bearings providing smooth, long term positive actuation.

2000-up Softail® FCK-S1CS-SR

1999-Earlier
Softail®
FCK-SOCS-FR



2000-up Dyna
FCK-D1CS-SR

1999-Earlier Softail®
FCK-SOCS-FR-S



HawgHalters.com

Local: 706-864-7800

Fax: 706-864-5843

389 Lumpkin County Parkway
Dahlonega, GA 30533

HYDRAULIC CLUTCH
FCH-SOCS-FP

- (FC) Forward Control
- (K) Complete Kit
- (B) Brake Side Only
- (S) Shifter Side Only
- (H) Hydraulic Clutch
- (S) Softtail
- (D) Dyna
- (C) FXR/Custom
- (F) FLH
- (0) 99-earlier, (1) 2000-06,
- (7) 2007, (8) 2008, (9) 2009
- (C) Chrome
- (P) Polish
- (A) Black Anodize

FCK-SOCS-SR-S

- Standard (S)
- Extended (E)

- Solid Plain Peg Set (SP)
- Solid Plain Peg Set w/ Slots (SS)
- Solid Plain Peg Set w/ Holes (SH)
- Solid Rubber Inlay Peg Set (SR)

- Folding Plain Peg Set (FP)
- Folding Plain Peg Set w/ Slots (FS)
- Folding Plain Peg Set w/ Holes (FH)
- Folding Rubber Inlay Peg Set (FR)

- Slotted Style Levers (S)
- Holes Style Levers (H)
- Elite Holes Style Levers (HE)

FCK-SOCS-SR-H

FCK-COAS-FR-HE



2000-up
FLH Standard
FCK-F1CS-FR

Bagger Forward Control Systems

HHI offers a complete line of forward controls designed specifically for the Bagger/Touring models. Kits are available in both standard and extended length versions for models 1997-2008. The 2009-up model design incorporates an adjustable peg position to accommodate most rider fitments.

These controls bolt right up without modifications and use the stock master cylinder for easy installation and service.

Both the shifter and brake pivot assembly incorporate dual sealed ball bearings providing a smooth, positive actuation for many miles to come.

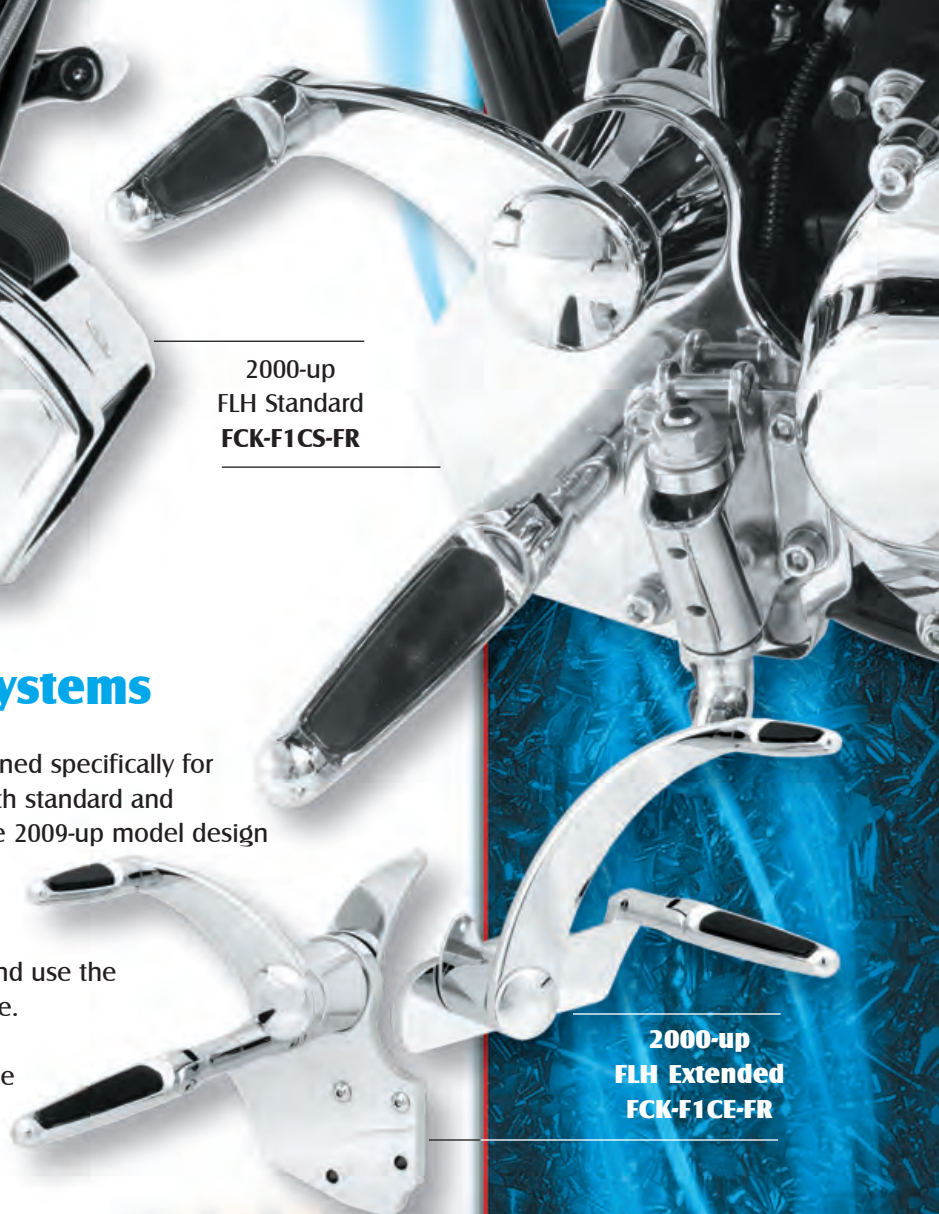

2000-up
FLH Extended
FCK-F1CE-FR



FCK-F9AS-FR-HE



HawgHalters.com

Local: 706-864-7800

Fax: 706-864-5843

389 Lumpkin County Parkway
Dahlonega, GA 30533

HellRazor HandleBar Systems

HHI now offers a custom handlebar system to help make your bike a one of a kind custom ride. We provide a complete fully assembled and wired system ready to install. All you have to do is mount the bars, plug in the connectors and enjoy the ride.

Full systems feature all internal wiring and cabling leaving nothing exposed. Compatible with cable style traditional throttle or late model electronic throttle by wire bikes.



BLACK STREET GLIDE
Shown with
14" SG REAPER bar

Handlebars integrate all stock control functions including audio volume and radio/CD selector AND Cruise Control.



RG REAPER



SG REAPER



RAIDER



DRAGGER



HellRazor HandleBar Systems

This total package results in a show winning combination and we do all the work. No more struggling with routing wires and cables inside your bars or worse yet having all that hanging in the wind. All bars assembled using stock H-D connectors.

HHi offers bars for most HD models in various styles and sizes. We custom build each one to order so you can choose your features, finishes and options.

**2011 ROAD GLIDE
Shown with our
10" Rg REAPER Bars
Featuring
25 degree pullback
and 10 degree drop**



HHi

HawgHalters.com

Local: 706-864-7800

Fax: 706-864-5843

389 Lumpkin County Parkway
Dahlonega, GA 30533

Hand Control Systems

To complement our Forward Controls, HHI comes through with a superbly styled and engineered Hand Control package. These matched designed controls provide you with a total package resulting in a show winning combination.

Check out the sleek lines, smooth curves, and hidden hardware all in a compact package. This is the design the industry has been looking for!

HCPA-CS
HBMA-CS21

HCPA-AS

HCMA-AS21

Our new hand control features a 9/16" master cylinder bore size for single disc applications and is compatible with most stock and aftermarket 4 and 6 piston calipers. We also offer an 11/16" bore for dual disc set ups and both utilize late model OEM type seals for assured performance and quick serviceability.

The clutch and brake lever pivots contain nylon bearings and spring loading for smooth, no rattle operation and long term performance. Other features include a recessed cover with a flex type seal for leak proof operation.

Controls fit 1" bars and are clearanced to

fit up to 1 1/2" diameter fat bars.

- (H) Hand Control
- (BMA) Brake
- (CPA) Mechanical Clutch
- (CMA) Hydraulic Clutch
- (C) Chrome
- (P) Polish
- (A) Black Anodized

HBMA-CS21

- Standard Lever (S)
- 9/16" Bore (1)
- 11/16" Bore (2)

HYDRAULIC TRANSMISSION CLUTCH HOUSING KIT

Necessary when converting to hydraulic clutch, our clutch housing kit is adaptable to most stock and aftermarket transmissions. Machined from solid billet aluminum, it operates best with our 9/16" bore hydraulic hand control.

HYCCA-C01 - 5 Speed Chrome

HYCCA-C02 - 6 Speed Chrome

HYCCA-A01 - 5 speed Black

HYCCA-A02 - 6 Speed Black

THROTTLE HOUSING

Designed to work with and compliment our switch housings.

(DC) Dual Cable

(SC) Single Cable

HTHA-DC-C01

Chrome (C)

Polish (P)

Black Anodized (A)

Early Style, Thread In (01)

Late Style, Snap In (02)

HAND CONTROL SWITCH HARNESS CONVERTER

Provides two latching relay functions for our momentary push buttons.

HSC-WP166 - Momentary Switch Converter, 2 Function

Direct plug in Converter Harness for stock HD.

HSCH-001 - 1996-06 H-D Softail/Dyna/ Sportster

HSCH-002 - 2007-up H-D Softail/Dyna/Sportster

HSCH-003 - 1996-06 H-D RoadKing

HSCH-004 - 2007-up H-D RoadKing

HSCH-005 - 1996 - 06 Touring

HSCH-006 - 2007 - up Touring

HAND CONTROL SWITCH HOUSING ASSEMBLY

Uniquely designed to match exclusively with our hand controls

HSHA-3C-LR - 3 Button Set, Chrome

HSHA-2C-LR - 2 Button Set, Chrome

HSHA-3A-LR - 3 Button Set, Black Anodized

HSHA-2A-LR - 2 Button Set, Black Anodized



A variety of Grip Sets are available with tapered bezels to match up with our custom switch housings.

HHi

HawgHalters.com

Local: 706-864-7800

Fax: 706-864-5843

389 Lumpkin County Parkway
Dahlonega, GA 30533

Complete Front Ends

HHI offers a comprehensive line of front end suspension products in a 41mm conventional fork. Front ends are available with HHI triple trees offered in various styles, finishes and rakes. Triple tree widths include both mid and wide glide. Fork tubes in any length up to 20" over stock. 41mm tubes use internal dampening components manufactured to OEM specs and fork tubes have the OEM hard chrome finish providing long term seal and bushing life. Lower legs are offered in a variety of styles and finishes allowing us to build the front end of your choice.

Choose the combination that is best suited for your project.



41mm
Torpedo Legs,
Chrome Slade Trees

41mm Bomber Legs Chrome Wide Glide Trees

41mm Black Torpedo Legs, Black Wide Glide Trees

(41) mm

(WG) Wide Glide, (MG) Mid Glide

(C) Chrome - available for all front ends.

(P) Polish, (M) Raw finish or (A) Black Anodize - Limited availability

(R) Rake is available in: (0)°, (3)°, (4)°, (5)°, and (6)°

41WGCR3-EFS-12ST-Y2-R

External Fork Stop for FXR, Dyna, XL (EFS)

Tube Length in Inches Over Stock FXST:

(0), (2), (4), (6), (8), (10), (12), (14), (16), (18), (20)

Brake Setup: Single (S) or Dual (D)

Fork Leg Style: 41mm: Torpedo (T), Bomber (B)

2000-up Caliper mount: Leave blank for 99-earlier (Y2)

Right side Brake: Leave blank for left side single disc (R)

Fork Stop Kits

- (EFS) External Fork Stop
- (HFS) Hidden Fork Stop

EFS-001

EFS Available for:

- (001) Stock Frame FXR/Dyna®/Sportster

HFS Available for:

- (001) 1988 & Earlier Big Twin & Custom
- (004) Custom frame with internal stop tab
- (005) Stock or Custom Frame without stop tab

HFS-005

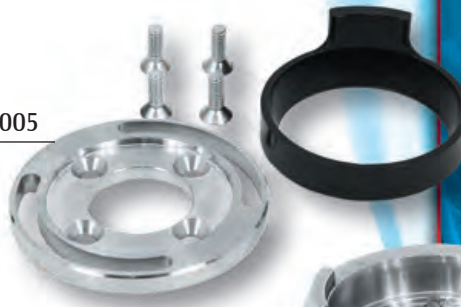

HFS-001



Triple Tree Conversion Kits

Available in (WG) Wide Glide and (MG) Mid Glide

- (CK) Conversion Kit

MGCK-001

- (001) 84-94, Single Disc, (002) 2000-Up, Single Disc
 - (003) 84-94, Dual Disc, (004) 2000-Up, Dual Disc
 - (007) 95-99, Single Disc, (008) 95-99, Dual Disc
 - (301) 04-05 Dyna, (306) 06-07 Dyna
- Many other applications available.



Riser Bushing Kits

Specially formulated Urethane for a firm but smooth feel. Flush mount design, polished finish. Coarse Thread (RB-001), Fine Thread (RB-002)



HHI

HawgHalters.com

Local: 706-864-7800

Fax: 706-864-5843

389 Lumpkin County Parkway
Dahlonega, GA 30533

Triple Trees

HHI offers an industry leading triple tree product line, precision made in our plant and treated to a variety of show quality finishes. Triple trees have a smooth top design hiding the fork tubes and neck stem for the true custom look. The lower tree utilizes hidden clamp bushings to secure the tubes in a clean, positive method.



Dial in the best trail for your application by choosing from a variety of rakes. Triple trees for 39mm are available in narrow, mid and wide glide widths. 41mm and 49mm fork triple trees are available in mid and wide glide widths. 39mm NG trees are stock H-D width and available for a lower mount headlight or stock upper visor mount. All trees are pre-drilled to accept a variety of optional internal fork stop kits. Trees can also be ordered with an external stop kit which is standard for the Sportster, Dyna and FXR models.

41mm trees are also available in our SLADE design which features a special radius angle machining providing an aggressive look accented by a unique reflective design.



41mm
Wide Glide,
Slade Style



41mm
Mid Glide
Black Anodize



39mm
Narrow Glide
- H option

Internal Brake Line Option (IBL)

Another option available is the internal brake line feature. Trees are drilled to allow your brake line to pass thru the top tree and connect to a fitting on the top of the lower tree. The lower tree is cross drilled to allow a separate lower brake line connection to either single or dual brake calipers.



(39) mm, (41) mm, (49) mm
-(WG) Wide Glide, (MG) Mid Glide,
(NG)* Narrow Glide, (FB) FatBoy/Heritage,
(C) Chrome, (P) Polish, (M) Raw (A) Black Anodize

41WGCRO-EFS

Classic Style (R), Slade Style (S)
Rake is available in:
39mm (0)°, (3)°, (4)°, (5)°
41mm (0)°, (3)°, (4)°, (5)°, (6)°, and (7)°
49mm (0)°, (3)°, and (5)°
Required for External Fork Stop (EFS)
Internal Brake Line option (I)
* Narrow Glide Only Available in 39mm

Fatboy/Heritage Triple Trees

Our Fatboy/Heritage raked triple tree has been engineered to accept the original tin covers and headlight maintaining the stock tree look while increasing the rake and wheelbase. Kits are available in both a 4° rake for two wheel applications offering that pro-street stance and a 6° rake providing easier steering for trike applications. These kits come with everything needed including extended length lower fork covers and fork tube insert plugs allowing you to retain the stock fork tubes.

Fatboy Trees with Lower Covers



FL Touring Raked Triple Tree

HD FL Touring model raked triple tree kits are designed for retrofit to all 1996-up FL model trike conversions.

These trees provide for a much easier steering trike and are available in both +3° and +5° rake for various trike applications.

41FLMR3 or 41FLMR5



Honda Goldwing Steering Kits

GL1500 & GL1800 available in either +4° or +6° rake kits.

41HGWMR4
GL1500 4° Kit

41HGWMR6
GL1500 6° Kit

45HGWMR4 - GL1800 4° Kit
45HGWMR6 - GL1800 6° Kit



HawgHalters.com

Local: 706-864-7800

Fax: 706-864-5843

389 Lumpkin County Parkway
Dahlonega, GA 30533 31

HHI

Wheels

HHI offers a complete lineup of premium forged billet wheel products manufactured by Renegade Wheels. Starting with an HHI exclusive design, the FUELIE wheel offers hot rod styling in either chrome or black anodized reverse cut machine finish. These wheels come completely assembled and ready to install on any HD model.

Matching design brake rotors are available in a one piece polished stainless steel or a two piece floating design with either a chrome or black anodized reverse cut billet center. Floating rotors are also stocked in 13" diameter for maximum braking performance.

Design cut belt pulleys and sprockets to match are also available to complete the set.



FUELIE

Available in Chrome or Black Ano-Reverse Cut, with matching Rotors and Pulleys

RENEGADE WHEELS



HHI is proud to be the exclusive Southeast Distributor for the complete line of Renegade Wheels premium forged billet wheel products. From the traditional one piece modular design to the multi-piece Elite Series, we have a complete array of styles and sizes providing you with the ultimate wheel selection.

Available finishes include chrome, polish, black powder coat and Phantom Series Black anodized. Wheels are delivered ready to install with fitments available for all HD models including cush drive and ABS models.

Matching design brake rotors are available in a two-piece cog design with matching design billet center.

WINSLOW



WHISTLER



**NEW
FOR
2012!**

HHI

HawgHalters.com

Local: 706-864-7800

Fax: 706-864-5843

389 Lumpkin County Parkway
Dahlonega, GA 30533

RENEGADE WHEELS



ROCKLIN



VAIL



ASPEN



TAHOE



Design cut
belt pulleys and
sprockets to match
are also in stock.

KINGMAN



WHISTLER



YUKON



SPEARFISH



CINCI



HawgHalters.com

Local: 706-864-7800

Fax: 706-864-5843

389 Lumpkin County Parkway
Dahlonega, GA 30533

RENEGADE WHEELS



PHOENIX



MONTEREY



VENICE

CHEYENNE



CABO



LAREDO

RACINE



Phantom-Cut Hand Polished

Black Anodized finish with
hand polished machined
surfaces for a stunning look.



CABO

RACINE



LAREDO



HawgHalters.com

Local: 706-864-7800

Fax: 706-864-5843

389 Lumpkin County Parkway
Dahlonega, GA 30533

RENEGADE WHEELS



ELITE SERIES WHEELS

Elite Series wheels offer the ultimate in choice when it comes to the style and appearance of your wheels. Choose any combination of finishes to provide a unique look for that special project bike.

WHISTLER



CHEYENNE

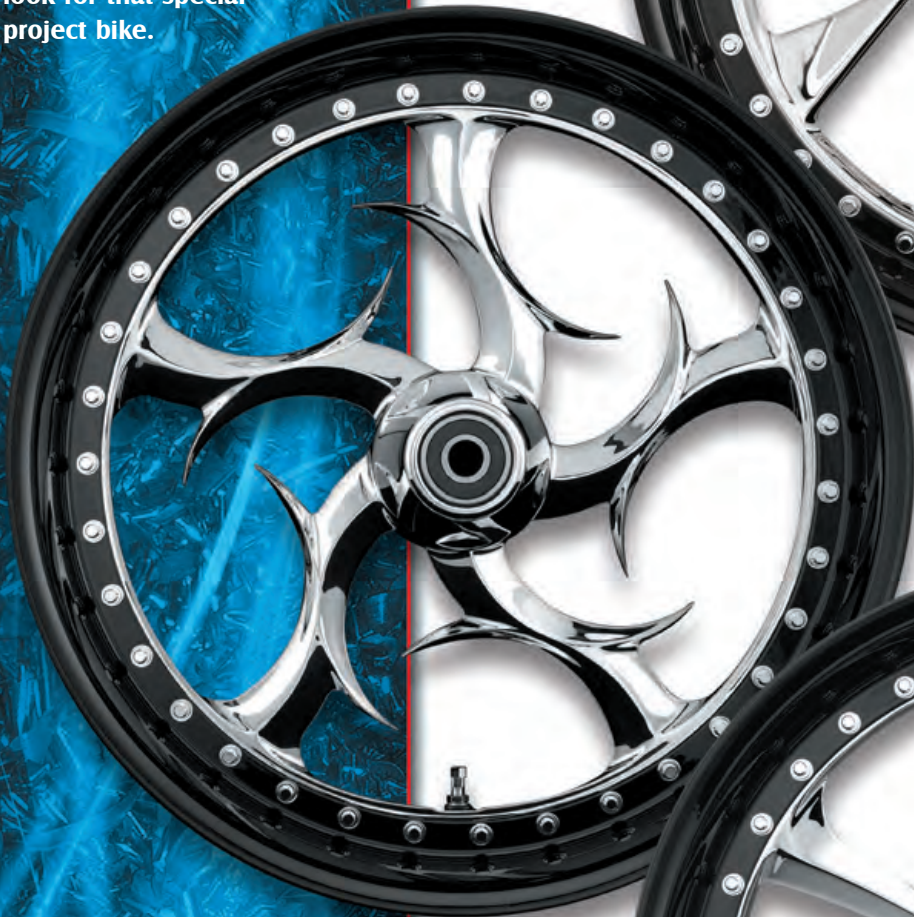

VAIL





ROCKLIN

TAHOE



ASPEN



HawgHalters.com

Local: 706-864-7800

Fax: 706-864-5843

389 Lumpkin County Parkway
Dahlonega, GA 30533

Bagger Central

Custom baggers are now the preferred choice for builders to show off their talents. We offer 21", 23", 26", and 30" all steel full wrap front fender kits, custom fork legs, single disc conversions and more to help you fully customize your bagger.



21", 23", 26" FLH Front Fender and **NEW** 30" Fender



FSK-C01



FSK-C05



Fender Spacer Kits

- FSK-C01** - Custom Fender on a 41mm FX Wide Glide - 1/2" thick
- FSK-C02** - Custom Fender on a 41mm FX Wide Glide - 3/4" thick
- FSK-C03** - Custom Fender on a 41mm FX Wide Glide - 1" thick
- FSK-C04** - 120/50-26" & 30" tire wrap fender on a FLH fork
- FSK-C05** - 120/70-21" tire wrap fender on a FLH fork
- FSK-C06** - 130/60-23" tire wrap fender on a FLH fork
- FSK-C07** - Stock FLH fender with a 130/60-23" tire or Stock FLH fender with a 140/70-21 tire or Stock 2010 - Later Screaming Eagle models with a 120/70-21" tire
- FSK-C08** - 2009 SE Road Glide fender with a 120/70-21" tire
- FSK-C09** - 2009 SE Road Glide fender with a 130/60-23" tire

Neck Rake Builder Kit

HHI now offers a weld-on replacement neck section for Bagger frames. This piece provides correct frame geometry for installing a 23", 26" or 30" wheel when installed with our FL raked triple trees. We provide this as a kit with our trees for the following applications:

- NRBK3-08** - 2008 - earlier FL with 23" wheel
- NRBK5-08** - 2008 - earlier FL with 26" wheel
- NRBK8-08** - 2008 - earlier FL with 30" wheel
- NRBK3-09** - 2009 - later FL with 23" wheel
- NRBK5-09** - 2009 - later FL with 26" wheel
- NRBK8-09** - 2009 - later FL with 30" wheel



Bagger Single Disc Conversion

Nothing does more to provide that custom Bagger look than a big front wheel and a single disc conversion from HHI. Choose from any of our wheel styles in 21", 23" or 26" sizes and match it up with a 13" floating rotor and 6 piston caliper to combine custom styling and great braking performance.

- Brake Hose Kit**
- BHK-008** - 2007 - earlier
- BHK-012** - 2008 - up

- WGA-009F** - 2007 - earlier
- WGA-009F-M** - 2008 - Up

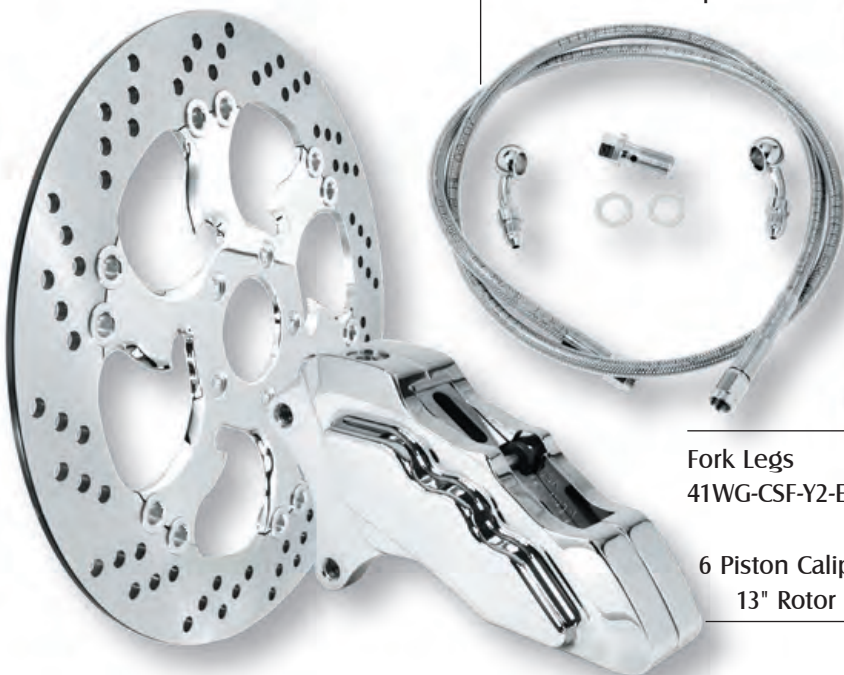

- Fork Legs**
- 41WG-CSF-Y2-EX**

- 6 Piston Caliper and**
- 13" Rotor Combo**



HawgHalters.com

Local: 706-864-7800

Fax: 706-864-5843

389 Lumpkin County Parkway
Dahlonega, GA 30533

Bagger Fork Leg Packages

HHI now offers billet fork leg sets for FLH models featuring a hidden axle, contoured axle spacers and an integrated fender/caliper mount featuring an adjustable height fender mounting system.

These kits are offered in chrome or black finish, single or dual disc, and a choice of two different axle end cap designs.



**FLH Bomber Fork Leg Set
Chrome Finish**

**FLH Bomber Fork Leg Set
Anodize Black**

**FLH Torpedo Fork Leg Set
Chrome Finish**

**Multiple
Fender
Mounting
Positions**



Coming To An Event Near You!

Check out the entire line of HHI products in person!
We invite you to schedule an installation of select parts -
including the complete line of Renegade Wheels!



HHI 2012 Event Schedule

Daytona Bikeweek, Daytona Beach, FL - 03/09/12 - 03/18/12

Set up @ Rossmeyers Harley-Davidson Destination Daytona

HHI SPRING BLING, Dahlonega, GA - 04/14/12

HHI Parking Lot-389 Lumpkin County Parkway

Leesburg Bike Fest, Leesburg, FL - 04/26/12 - 04/29/12

Set up at Gator Harley-Davidson

Thunder Beach Spring Motorcycle Rally, Panama City, FL - 05/02/12 - 05/06/12

Set up @ Frank Brown Park

Myrtle Beach Spring Rally, Myrtle Beach, SC - 05/11/12 - 05/20/12

Set up @ Spokes and Bones

Laconia Motorcycle Week, Meredith/Laconia, NH - 06/09/12 - 06/17/12

Set up @ Laconia Harley-Davidson

Sturgis Rally, South Dakota - 08/06/12 - 08/12/12

Set up @ Rapid City Black Hills Harley-Davidson

Ocean City BikeFest, Ocean City, MD - 09/13/12 - 09/16/12

Set up @ The Boardwalk

Street Vibrations, Reno, NV - 09/19/12 - 09/23/12

Set up TBD

Bikes, Blues & BBQ, Rogers, AR - 09/26/12 - 09/29/12

Set up @ Pig Trail Harley-Davidson

Thunder Beach Fall Motorcycle Rally, Panama City, FL - 10/10/12 - 10/14/12

Set up @ Frank Brown Park

Daytona Biketoberfest, Daytona Beach, FL - 10/18/12-10/21/12

Set up @ Rossmeyers Harley-Davidson Destination Daytona

Galveston Lone Star Rally, Galveston, TX - 11/01/12 - 11/04/12

Set up @ 25th & Mechanic Street

HHI

HawgHalters.com

Local: 706-864-7800

Fax: 706-864-5843

389 Lumpkin County Parkway
Dahlonega, GA 30533



Burnouts!



Visit **HHi-**

Spring Bling!

Held The Second
Saturday Every April.

**Live
Band!**



- "Ride In" Bike Show
- Hot Food, Cold Beer
- Entertainment
- Cash & Prizes!
- New Products
- Fun for the Family!

Check on the website
for the latest details...



**Family
Fun!**



**The Latest in
New Products!**

HHi

HawgHalters.com

Toll Free: 877-442-5837

Local: 706-864-7800

Fax: 706-864-5843

389 Lumpkin County Parkway
Dahlonega, GA 30533